

STYLELINE® DOOR HINGE ASSEMBLY REPLACEMENT

Top Hinge Repair Kit

- Part 2907 for Classic® doors
- Part 5705 for S//E® doors

1. Remove door from frame.
 - Holding the top hinge pin with a 5/16" wrench, loosen the lock nut with an 11/16" wrench. This will release the spring tension.
 - Open the door and remove the two screws from the door plug. If a cord is present, unplug the cord from the frame.
 - With the door open about 90 degrees, lift the hold open cam off the slide pin.
 - Lift the door up and out off the bottom hinge pin.
2. Remove the retainer ring from the top hinge hole by compressing the open ends together.
3. Pull the top hinge bushing from the door. If bushing is still attached to the torque rod, do not pull the torque rod more than 6" out of the door. If the bushing is not attached to the torque rod, pull the torque rod from the top hinge hole, but not more than 6".
4. To replace the top hinge bushing, hold the torque rod and pull old bushing off. (NOTE: If bushing is black, remove old spring from torque rod and slide new spring and washer in place. If bushing is not black, do not remove spring). To install new top hinge bushing, align square of torque rod to square hole in top hinge bushing and tap onto torque rod. Torque rod should be inserted at least 1" into bushing.
5. The torque rod and hinge bushing can now be pushed back into the door. Top hinge bushing should be deep enough into the hinge block to expose retainer clip groove. If groove is not visible, then the top hinge bushing is not far enough on the torque rod. Once the groove is visible, replace the retainer ring by compressing the open ends.

CAUTION: Before replacing door, remove existing nylon washer from the bottom hinge pin and install a new washer in its place.
6. Replace door by engaging top hinge pin into to bushing of door and lift door over bottom hinge pin, allowing door to drop into proper position.

7. Reconnect the door plug if it was removed.
8. Adjust the door tension:
 - Using a 5/16" wrench on top hinge pin, turn toward direction of door closing to increase tension.
 - Tighten top lock nut with an 11/16" wrench.
 - Repeat above steps until desired tension is obtained.

NOTE: If the top hinge bushing squeaks or binds, pull the bushing out and lightly sand the outer surface with fine sandpaper. Apply a light coating of oil and replace bushing.

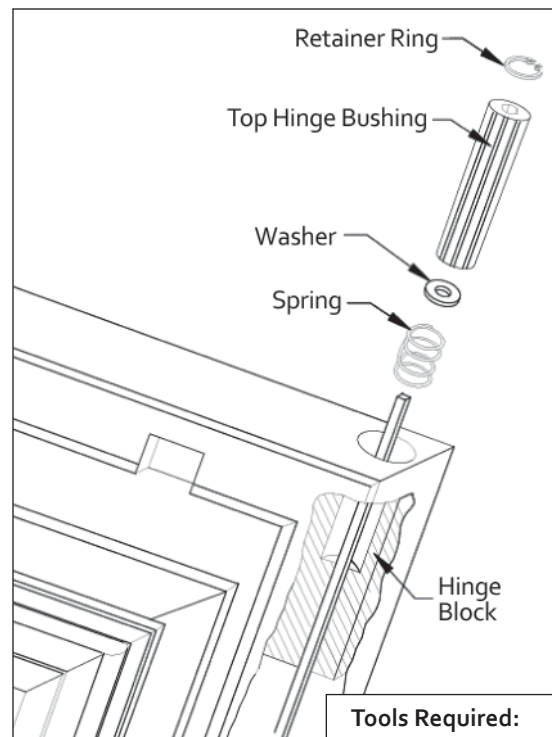

- Tools Required:**
- 5/16" Wrench
 - 11/16" Wrench
 - Hammer
 - Retainer Ring Pliers



800-237-3940 • sales@STYLELINE.com • www.STYLELINE.com

